

# GERMAN INSTITUTE FOR STRUCTURAL ENGINEERING

Public Institution

10829 Berlin, 22 January 2008  
Kolonnenstrasse 30 L  
Telephone: 030 78730-356  
Fax: 030 78730-320  
Office: I 23-1.21.4-75/07

## General Building Approval

**Approval number:** Z-21.4-151

**Client:** Deutsche Kahneisen Gesellschaft mbH  
Nobelstrasse 51/55  
12057 Berlin

**Subject of the Approval:** Jordahl anchor rails type JTA and JTA-R

**Applicable until:** 31 January 2013

The subject of the Approval mentioned above is hereby granted General Building Approval.\*

This General Building Approval comprises thirteen pages and 16 annexes.

*Note:*

*Translation of the German original version not checked by the German Institute for Structural Engineering*

*Every page of the German original bears the official stamp of the German Institute for Structural Engineering*

---

\* This General Building Approval replaces the general building approval dated 6 January 2003.

\* The subject was approved for the first time on 10 July 1979 in terms of a general building/planning and construction law approval.

# GERMAN INSTITUTE FOR STRUCTURAL ENGINEERING

Public Institution

10829 Berlin, 6 January 2003  
Kolonnenstrasse 30 L  
Telephone: 030 78730-356  
Fax: 030 78730-320  
Office: I 23-1.21.4-60/02

## General Building Approval

**Approval number:** Z-21.4-151

**Client:** Deutsche Kahneisen Gesellschaft mbH  
Nobelstrasse 51/55  
12057 Berlin

**Subject of the Approval:** Jordahl anchor rails type JTA and JTA-R

**Applicable until:** 31 December 2007

The subject of the Approval mentioned above is hereby granted General Building Approval.\*

This General Building Approval comprises thirteen pages and 16 annexes.

*Note:*

*Translation of the German original version not checked by the German Institute for Structural Engineering*

*Every page of the German original bears the official stamp of the German Institute for Structural Engineering*

- 
- This General Building Approval replaces the general building approval dated 4 December 2001.
  - The subject was approved for the first time on 10 July 1979 in terms of a general building/planning and construction law approval.

## I. GENERAL PROVISIONS

- 1 The General Building Approval demonstrates the ability to use and apply the subject of the Approval in the sense of the regional building regulations.
- 2 The General Building Approval does not replace the approvals, agreements and certificates prescribed by law for the implementation of building projects.
- 3 The General Building Approval is granted regardless of the rights of third parties, in particular private protective rights.
- 4 Parties manufacturing and marketing the subject of the Approval must, irrespective of further-reaching regulations in the "Special Provisions", make copies of the General Building Approval available to those using or applying the subject of the Approval and point out that the General Building Approval must be present at the point of use. If required, copies of the General Building Approval must be made available to the authorities involved.
- 5 The General Building Approval may be copied only in full. Any publication of an extract requires the agreement of the German Institute for Structural Engineering. Texts and drawings in advertisements must not contradict the General Building Approval. Translations of the General Building Approval must contain the note "Translation of the German original version not checked by the German Institute for Structural Engineering".
- 6 The General Building Approval is granted until revoked. The provisions of the General Building Approval can subsequently be supplemented and changed, in particular when new technical findings require this.

## II. SPECIAL PROVISIONS

### 1. Subject of the Approval and area of application

#### 1.1 Subject of the Approval

The Jordahl anchor rail type JTA and JTA-R made of steel and of stainless steel comprises a C-shaped rail with and least two anchors welded onto the back of the profile (type JTA) or round anchors pressed or welded on (type JTA-R).

The rail is concreted in flush with the surface. Hammer-shaped or hook-head-shaped bolts are inserted into the rail, to which any desired constructional parts can be fixed.

The anchor rail is illustrated in the installed state in Annex 1.

#### 1.2 Area of application

The anchor rail may be used for anchoring means under predominantly steady loading in reinforced or non-reinforced standard concrete of strength class of at least B15 DIN 1045:1988-07 "Concrete and reinforced concrete, dimensioning and execution" or lightweight concrete (dense structure)  $\geq$  LB25 (addition of expanded clay, expanded slate or pumice); it may also be used in concrete of strength class of at least C12/15 or lightweight concrete (dense structure)  $\geq$  LC25/28 (addition of expanded clay, expanded slate or pumice) to DIN EN 206-1:2001-07 "Concrete; Part 1: Definition, properties, production and conformity" in conjunction with DIN 1045-2:2001-07 "Load-bearing structures of concrete, reinforced concrete and prestressed concrete, Part 2: Concrete - Definition, properties, production and conformity". In the event of requirements on the fire resistance of the concrete components in which the anchor rails are anchored, the restrictions according to Section 3.2.7 must be noted.

The profiles W 40/22/2.5 and W 40/22; W 50/30/3.0 and W 50/30; W 54/40/4.0 and W 53/34 and W 74/48/5.0 and W 74/48 made of material 1.0038 in the design with transversely welded-on I anchors and also the profiles W 40/22 and W 50/30 made of the material 1.0038 in the design with pressed round anchors (type R1 and R3) may be used in reinforced standard concrete of strength class of at least B15 or C12/15 even under a not predominantly stable central tensile loading.

In the case of anchoring in the tension zone of the concrete produced by load stresses or if the minimum spacings of the anchor rails are used, the local transverse tensile stresses occurring as a result of the springing action must be absorbed by additional reinforcement, if constructive measures or other beneficial influences (e.g. transverse pressure) do not prevent the concrete splitting.

The corrosion prevention measures of the anchor rails (rail, anchor, bolt, nut and washer) must be complied with in accordance with Annex 8 and Section 3.1.2, depending on the area of application and the environmental conditions.

A galvanized anchor rail may be connected to reinforcement only when the temperature of the contact points between the reinforcement and the galvanized steel parts does not exceed 40°C.

In the case of prestressed concrete components, the spacing of a galvanized anchor rail from the enveloping tubes of the stressing element or the stressing wire with immediate composite action must be at least 2 cm.

## **2 Provisions for the structural product**

### **2.1 Properties and composition**

The constructional parts of the anchor rails (rail, anchor, bolt, nut and washer) must correspond to the drawings and specifications in the Annexes.

The material characteristics, dimensions and tolerances of the anchor rails and bolts not specified in this General Building Approval must correspond with the specifications deposited at the German Institute for Structural Engineering, at the certification office and at the third-party monitoring office.

For the rails, the material and the material properties must be documented by means of a works test certificate 2.3 according to DIN EN 10 204:1995-08.

For the anchors, the material and material properties must be documented by a works certificate 2.2 according to DIN EN 10 204.

For the bolts, the dimensions and material properties must be documented at least by a works test certificate 2.3 according to DIN EN 10 204, unless the bolts are identified with strength class and manufacturer's symbol according to DIN EN ISO 898-1:1999-11.

The hexagon nuts with dimensions according to DIN EN ISO 4032:2001-03 or DIN EN ISO 4034:2001-03 must correspond to the strength class 5 according to DIN EN 20898-2:1994-02 or A4-50 or A4-70 according to DIN EN ISO 3506-02. For the hexagon nuts according to DIN EN ISO 4032:2001-03 or DIN EN ISO 4034 (previously: DIN EN 24032:1992-02 or DIN EN 24034:1992-02), a certificate of conformity (ÜZ) corresponding to construction rules list A, Part 1, index number 4.8.11 or 4.8.9 is required.

The washer with dimensions according to DIN 125-1:1990-03 must correspond at least to the material No 1.0037 (S235JR; St 37-2) according to DIN EN 10 025:1994-03 and stainless steel according to DIN EN 10 088 (material specification according to Annex 6 and 7). For the washer according to DIN 125, a manufacturer's certificate of conformity (ÜH) corresponding to construction rules list A, Part 1, index number 4.8.43 is required.

In addition, the provisions of the General Building Approval Z-30.3-6 "Components and connecting elements of stainless steels" must be complied with.

### **2.2 Manufacture and identification**

#### **2.2.1 Manufacture (connection between rail and anchor)**

The production of the connections (welding on, pressing) between anchor and rail is to be performed in the factory. One exception is formed by the end anchor according to Section 4.1.1, which is to be fitted subsequently on the building site.

For welding on the anchors (type JTA), the inert gas welding process MAD/MAGM (process 135 according to DIN EN ISO 4063:2000-04) is to be used. The round anchors (type JTA-R/R2) are to be welded onto the rear of the anchor rails by means of short-term stud welding with displacement ignition (process 784 according to DIN EN ISO 4063:2000-04).

For connections between stainless steels and less alloyed structural steels, the Special Provisions of the General Building Approval "Components and connecting elements of stainless steels" (Z-30.3-6) must be complied with. The welds must be formed in accordance with Annexes 4 and 5.

With regard to the verification of suitability of the operation, DIN 18 800-7:2002-09 "Steel structures, Part 7: Design and manufacturer qualification" and the "Manufacturing guideline for steel construction", issue dated March 1996, Communications of the German Institute for Structural Engineering, special issue number 11/1, apply. To secure the quality of the round anchor welded connections, DIN EN ISO 14 555:1998-12 "Welding - arc stud welding of metallic materials" applies.

The round anchors (type JTA-R/R1 and R3/) are plugged through a hole prefabricated in the rear of the rail and pressed, at the factory.

#### 2.2.2 Marking

Each delivery note of the anchor rails and bolts must be marked by the manufacturer with the compliance symbol (Ü symbol) in accordance with the compliance symbol regulations of the German regions. In addition, the works code, the approval number and the complete description of the anchor rails and bolts must be specified on the delivery note.

The marking may be carried out only if the preconditions according to Section 2.3, Verification of compliance, have been satisfied.

The anchor rail is described in terms of the type of manufacture (cold-formed or hot-rolled) and the profile dimensions (width/height) in mm, e.g. profile JTA K 28/15. The addition of the material thickness (e.g. JTA K 28/15/2.3) is optional.

Each hook-head bolt (types A, B and C) and hammerhead bolt (types D and H) must be embossed with the works code and the strength class according to Annex 6, e.g. DKG 4.6 or DKG A4-50.

Each hook-head bolt (types JA; JB; JC and JE) and hammerhead bolt (types JD and JH) is to be embossed with the works code and the strength class according to Annex 7, e.g. JB 4.6. The stainless steel bolt is additionally embossed as follows, depending on the material number: material numbers 1.4401, 1.4404 and 1.4501, additional embossing "A4", e.g. JB A4-50; material No 1.4529, additional embossing "KK", e.g. JB KK-50; and material number 1.4462, additional embossing "FA", e.g. JB FA-70.

The stainless steel hexagon nuts and washers for corrosion resistance class IV must additionally be identified as follows: 1.4529 with "KK" and 1.4462 with "FA".

Each anchor rail must be marked in accordance with Annex 8.

## 2.3 Verification of compliance

### 2.3.1 General

The confirmation of the compliance of the anchor rails and bolts with the provisions of this General Building Approval must be carried out for each factory with a certificate of compliance on the basis of in-house production control and regular third-party monitoring, including initial testing of the anchor rails and bolts in accordance with the following provisions.

In order to grant the certificate of compliance and the third-party monitoring, including the product tests to be carried out in the process, the manufacturer of the anchor rails and bolts has to involve a certification authority recognized for this purpose and also a monitoring authority recognized for this purpose.

The German Institute for Structural Engineering must be provided by the certification authority with a copy of the certificate of compliance granted by them, for information.

The German Institute for Structural Engineering must additionally be provided with a copy of the initial testing report, for information.

### 2.3.2 In-house production control

In each factory, in-house production control must be set up and carried out. In-house production control is understood to mean the continuous monitoring of the production to be performed by the manufacturer, with which it is ensured that the structural products produced by it correspond with the provisions of this General Building Approval.

The in-house production control should include at least the measures listed below.

Description and checking of the raw material and the constituent parts:

- For the constructional parts of the anchor rail (rail, anchor, bolt, nut and washer), the verification of compliance required in accordance with Section 2.1 and test certificates must be checked for completeness and correctness.
- The dimensions and material properties of the bolts must be checked continuously by the factory in accordance with DIN ISO 8992 and DIN EN ISO a 898 and DIN EN ISO 3506-1.
- Determination of the functional dimensions (thickness, width, height and opening) of the rails and anchors and comparison with the values specified in the Annexes.

Verifications and tests which must be carried out on the finished structural product, at least on three samples per 2000 running metres of anchor rails or per 10 000 short pieces or once per production week in each case:

- In the mass production of the anchor rails with the round anchor type R1 or R3, after setting up or changing over, the tests must be performed immediately on at least three samples. If the prescribed dimensions and loads at fracture are complied with, the testing can be reduced to one sample per 2000 running metres or per 10 000 short pieces.
- In the case of rails produced in a dedicated factory, the functional dimensions must be determined and compared with the values specified in the Annexes.

- Checking of the weld thicknesses, weld lengths, anchor widths and anchor axial spacings and comparison with the values specified in the Annexes.
- Checking of the bolt seating in the rail and of the assembly carried out properly.
- Determination of the load at fracture of the anchors in the central tension test on rail sections with anchors in the design made of steel, possibly following galvanizing, and stainless steel of corrosion resistance classes III and IV. Here, the loads at fracture must not fall below the following values:

Profile	Load at fracture [kN]
K 28/15; K 28/15/2.3	8.8
K 38/17; K 38/17/3.0	17.5
K 40/25; K 40/22/2.5 K 41/25/2.5 W 40/22; W 40/22/2.5	20
K 50/30; K 50/30/3.0 W 50/30; W 50/30/3.0	30
K 53/34; K 54/40/4.5 W 53/34; W 54/40/4.0	55
W 54/43 K 72/48 W 74/48; W 74/48/5.0	67.5

- The determination of the layer thickness of the corrosion protection is to be carried out in accordance with or following the model of DIN EN ISO 4042:1999-10 with a layer thickness measuring instrument. In the case of bought-in parts (third-party galvanizing), the testing must be carried out even when there is a certificate from the supply company relating to tests.

The results of the in-house production control must be recorded and evaluated. The recordings must contain at least the following information:

- Designation of the structural product or of the raw material and the constituent parts
- Type of inspection or testing
- Date of manufacture and testing of the structural product or the raw material or the constituent parts
- Result of the inspection and tests and, if relevant, comparison with the requirements
- Signature of the person responsible for the in-house production control.

The recordings must be kept for at least five years and presented to the monitoring authority involved in the third-party monitoring. They must be presented to the German Institute for Structural Engineering and the responsible highest building inspection authorities on demand.

In the event of an inadequate testing result, the requisite measures for rectifying the deficiency must be taken by the manufacturer without delay. Structural products which do not meet the requirements must be handled in such a way that confusion with identical parts is ruled out. After the deficiency has been rectified - to the extent technically possible and required

in order to verify the elimination of the deficiency - the existing testing must be repeated without delay.

### 2.3.3 Third-party monitoring

In each factory, the in-house production control must be checked regularly, but at least twice per year, by a third-party monitoring authority.

Within the context of the third-party monitoring, initial testing of the anchor rails and bolts must be carried out, and samples must also be taken for random sample tests. Sampling and testing is in each case the responsibility of the recognized monitoring authority.

The third-party monitoring must be carried out on at least three examples in each case for each size manufactured, as follows:

- Determination of all the dimensions of the rails, anchors, bolts and welds and comparison with the values specified in the Annexes
- Determination of the load at fracture of the anchors in the central tension test on rail sections with anchors in the design made of steel, if appropriate following galvanizing, and stainless steel of the corrosion resistance classes III and IV. In the process, the loads at fracture must not fall below the values corresponding to the table in Section 2.3.2
- Determination of the layer thickness of the corrosion protection in a galvanized design of the rails, anchors and bolts
- Checking the defined codes and embossing.

The results of the certification and third-party monitoring must be kept for at least five years. They must be presented by the certification authority or the monitoring authority to the German Institute for Structural Engineering and the responsible highest building inspection authorities on demand.

## 3 Provisions for design and dimensioning

### 3.1 Design

#### 3.1.1 General

The anchoring must be planned by engineers. Taking account of the loads to be anchored, checkable calculations and design drawings must be prepared. The design drawings must contain precise specifications relating to position, size and length of the anchor rails and the bolt type and the size of the associated bolts.

#### 3.1.2 Corrosion prevention

The areas of application of the anchor rail (rail, anchor, bolt, nut and washer) are specified in Annex 8, Table 9 as a function of the corrosion prevention measure (design lines 1 to 5). The electrogalvanized end anchors may be used only for areas of use in the designs according to lines 1 and 2 of Table 9, Annex 8. For the area of use of the design according to line 4 (corrosion resistance class III) of Annex 8, end anchors of stainless steel (1.4571/1.4401) must be used. In designs in corrosion resistance class IV, no end anchors may be used.

The anchor rails with welded-on anchors, in which the rail, bolt, nut and washer consist of stainless steel, material numbers 1.4401, 1.4404 and 1.4571, and the anchor of plain rolled steel (line 4 Table 9, Annex 8), may

also be used for constructions in corrosion resistance class III in accordance with the General Building Approval "Components and connecting elements of stainless steels" Z-30.3-6; that is to say they may be used in wet rooms and in the open air, also in an industrial atmosphere and close to the sea (but not in the range of influence of seawater), as long as further corrosion loadings do not occur. With regard to the corrosion prevention of the welded-on anchors, the cement covering "c" according to Annex 8, Table 10 may be used as a basis.

The anchor rail in which all the constructional parts (rail, anchor, bolt, nut and washer) consist of stainless steel, material numbers 1.4401, 1.4404 and 1.4571 (line 4 Table 9, Annex 8) may also be used for constructions in corrosion resistance class III in accordance with the General Building Approval "Components and connecting elements of stainless steels" Z-30.3-6; that is to say they may be used in wet rooms and in the open air, also in an industrial atmosphere and close to the sea (but not in the range of influence of seawater), as long as further corrosion loadings do not occur.

The anchor rail in which the constructional parts rail and anchor consist of stainless steel, material numbers 1.4529, 1.4547 and 1.4462 and, for the bolt, nut and washer, consist of the materials 1.4529 and 1.4462 (line 5 Table 9, Annex 8) may also be used for constructions in corrosion resistance class IV in accordance with the General Building Approval "Components and connecting elements of stainless steels" Z-30.3-6; that is to say they may also be used in regions in which, because of the increased concentration of pollutants, there is a very high corrosion loading. The anchor rail in which all the constructional parts consist of the material 1.4462 and the rail which consists of the materials 1.4529/1.4547 in combination with bolts, nuts and washers made of the material 1.4462 may not be used in swimming bath atmospheres.

## 3.2 Dimensioning

### 3.2.1 General

The anchoring must be dimensioned by engineers. The verification of the immediate local introduction of force into the concrete is adduced.

If the anchor rail is dimensioned in accordance with DIN 1045-1:2001-07 "Load-bearing structures of concrete, reinforced concrete and prestressed concrete, Part 1: Dimensioning and design", the stress dimensional value is to be set as follows:

$$F_{Rd} = \text{perm. } F \times 1.4$$

The passing on of the loads to be anchored in the component must be verified.

The weakening of the concrete cross section by the installation of anchor rails must be taken into account in the static verification, if appropriate.

Flexural stressing may remain unconsidered only if all the following conditions are met:

- The component to be connected consists of metal and is braced against the rail without any interlayer and
- the hole diameter in the component to be connected does not exceed the values according to Annex 10, Table 14.

Additional stresses which arise in the anchor rail, in the component to be connected or in the component in which the anchor rail is anchored as a result of a shape change being prevented (e.g. when the temperature changes) must be taken into account.

Stress components parallel to the rail axis are not permissible.

If smaller bolts are used, the permissible load on the bolts (Table 13, Annex 10) must not be exceeded.

The action of the individual load or the pair of loads can take place at any arbitrary point on the anchor rails. The axial spacings of the load action points (bolts) are specified in Annex 10. The axis of the bolt must be at least 2.5 cm away from the end of the rail.

The minimum spacings of the anchor rails (axial, edge and corner spacings) and component dimensions (component width and thickness) according to Annex 9 must not be undershot.

### 3.2.2 Permissible loads

The permissible loads are specified in Annex 10 as a function of the rail length, the stressing directions perpendicular to the rail axis (central tension, oblique tension and transverse tension), the spacings and the associated bolts M8 to M30 for the concrete strength classes  $\geq B25$  and  $\geq C20/25$ . In the case of anchoring in concrete in strength class B15 or C12/15, the permissible loads for B25 and C20/25 must be reduced by the factor 0.7; in the case of lightweight concrete (dense structure)  $\geq LB25$  or  $\geq LC25/28$  by the factor 2/3.

### 3.2.3 Flexural stressing of the bolts

The permissible bending moments are specified in Annex 10. The computational clamping point is the upper edge of the anchor rail.

In the case of bending with an additional central tension or oblique tension, the stresses must be superimposed:

$$F_z = \text{perm. } F (1 - M/\text{perm. } M)$$

perm. F = permissible central tensile load on the bolt according to Annex 10

perm. M = permissible bending moment on the bolt according to Annex 10

$F_z$  = existing tensile load component

M = existing bending moment.

In the case of façade cladding with variable flexural stresses (e.g. as a result of temperature changes), the alternating stress amplitude  $\sigma_A = + 50 \text{ N/mm}^2$  about the average  $\sigma_M$ , based on the computational stress cross section of the bolt, must not be exceeded.

### 3.2.4 Non-predominantly stable central tensile loads in reinforced standard concrete $\geq B15$ or $\geq C12/15$

For stress resulting from non-predominantly stable central tensile loads with a load cycle  $N \leq 2 \cdot 10^6$ , the anchor rails W 40/22; W 40/22/2.5; W 50/30, W 50/30/3.0; W 53/34; W 54/40/4.0; W 74/48 and W 74/48/5.0 made of the material 1.0038 (St 37-2) with transversely welded-on I anchors and the

anchor rails W 40/22 and W 50/38 made of the material 1.0038 with the round anchors R1 and R3 may be used. The permissible cycle size with a load cycle of  $N = 2 \cdot 10^6$  can be taken from Table 15 of Annex 11. With fewer load cycles, the permissible cycle size is to be taken from the graph of Annex 11 only for the profiles W 40/22; W 40/22/2.5; W 50/30 and W 50/30/3.0. The rails may be anchored only in reinforced standard concrete of at least B15 or C12/15. Only the associated bolts according to Annex 10, Table 12 are permissible.

### 3.2.5 Special case of narrow reinforced concrete components

An anchor rail arranged in the end of at least 10 cm thick, lightly loaded reinforced concrete components (e.g. façade panels, weakly stressed walls) may be stressed with central tension with the permissible load according to Annex 10, Table 12 if additional reinforcement according to Annex 12 is provided.

### 3.2.6 Displacement behaviour

Given a loading at the level of the permissible load, the following displacements in the direction of the load may be expected:

- profile W 54/43 and W 74/48  $\leq 0.8$  mm
- all other profiles  $\leq 0.6$  mm.

In the case of transverse loads, the hole play present between bolt and fitted part must be taken into account.

### 3.2.7 Fire protection

In the event of requirements on the fire resistance of the concrete components, the anchor rails may be stressed under predominantly stable loading at right angles to the rail axis (central tension, oblique tension and transverse tension) in reinforced and unreinforced standard concrete of strength class of at least B15 or C12/15. The permissible loads for the individual anchor rails are specified as a function of the bolt size for the fire resistance period of 90 minutes (F90) and 60 minutes (F60) in Annex 13, Table 16, and must not be exceeded. If the fitted part is fixed to the anchor rail by being mounted at a distance, the anchor rail may be loaded only in central tension when stressed by fire.

The anchor rails may be used for reinforced concrete floors stressed by fire on one side, reinforced steel beams stressed by fire on three sides and for reinforced concrete columns stressed by fire on four sides. In the case of reinforced concrete floors stressed by fire on one side, the minimum axial spacing of the tensile reinforcement in the region in the anchor rails according to Annex 14, Table 17 must be maintained. For reinforced concrete beams and reinforced concrete columns, the axial spacing "u" required by DIN 4102-4 for the reinforcement must be increased by the dimension " $\Delta u$ " specified in Tables 18 and 19 of Annexes 15 and 16.

If the anchor rails are incorporated in concrete components (reinforced concrete floors, beams and columns) in fire resistance class F60 or F90, and in the conditions specified in Annexes 13 to 16 are met, the fire resistance class of the concrete component is maintained.

The assessment of the fire resistance period for the construction to be connected is not the subject of this Approval.

## **4 Provisions for the implementation**

### **4.1 Installation of the anchor rails**

With the exception of the additional end anchors (4.1.1), no anchors may be fixed to the anchor rail, nor other changes made.

The installation of the anchor rail is to be performed in accordance with the design drawings produced in accordance with Section 3.1.1. The anchor rails are to be fixed to the shuttering in such a way that they are not displaced when the reinforcement is laid, nor during the introduction and compaction of the concrete. In the region of the rails and under the head of the anchors, the concrete must be compacted satisfactorily. The anchor rails must be protected against the penetration of concrete into the interior of the rails.

#### **4.1.1 Installation of subsequent end anchors (clamping part and bolt)**

In special cases, the profiles K28/15; K28/15/2.5; K38/17; K38/17/3.0; W40/22; W40/22/2.5, K40/25, K40/22/2.5 and K41/25/2.5 can be cut to length on the building site.

As a replacement for the anchors which are omitted, the end anchors specified in Annex 4 are to be provided. For the profiles K28/15 and K28/15/2.5, the end anchor type 1 with the M8 bolt and, for the other profiles, the end anchor type 2 with the M10 bolt must be used. The electrogalvanized end anchors may be used only for areas of use of the design according to lines 1 and 2 of Table 9, Annex 8. For the area of use of the design according to line 4 (corrosion resistance class III) Annex 8, end anchors of stainless steel, material numbers 1.4571/1.4401 must be used. In designs in corrosion resistance class IV, no end anchors may be used.

During assembly, the clamping parts must be pushed on to the ends of the anchor rails as far as the stop. The bolts must be tightened with a checked torque wrench with a torque of 10 Nm for the M8 bolt and 20 Nm for the M10 bolt.

### **4.2 Fixing the connecting construction (bolt mounting)**

The required bolt size must be taken from the design drawings. If, as a result of improper concreting or the like, the front edge of the anchor rail is not flush with the surface of the concrete, then this interspace must be lined completely during the mounting of the connecting construction.

The heads of the bolts are inserted into the slot in the rail, following clockwise rotation through 90° must rest completely on both legs of the anchor rail and must be locked by tightening the nut with the torque wrench. The tightening torques specified in Annex 10, Table 13 must be complied with.

Following the mounting, correct seating of the bolt must be checked; the marking slot at the shank end of the bolt must lie transversely with respect to the longitudinal direction of the rail. The axial spacing of the bolts must not fall below the specifications in Annex 10.

### **4.3 Monitoring the implementation**

During the installation of the anchor rails and during the mounting of the bolts (fixing of connecting constructions), the contractor entrusted with the anchoring of anchor rails or the construction manager commissioned by him

or a specialist representative of the construction manager must be present on the building site. He must ensure the proper implementation of the work.

In particular, he must monitor the implementation and position of the anchor rails and any possible rear-suspended reinforcement.

The recordings must be available during the construction period on the building site and must be presented to those entrusted with the supervision on demand. Just like the delivery notes, they must be kept for at least five years by the contractor after the work has been completed.

Latenser

Certified

[signature]

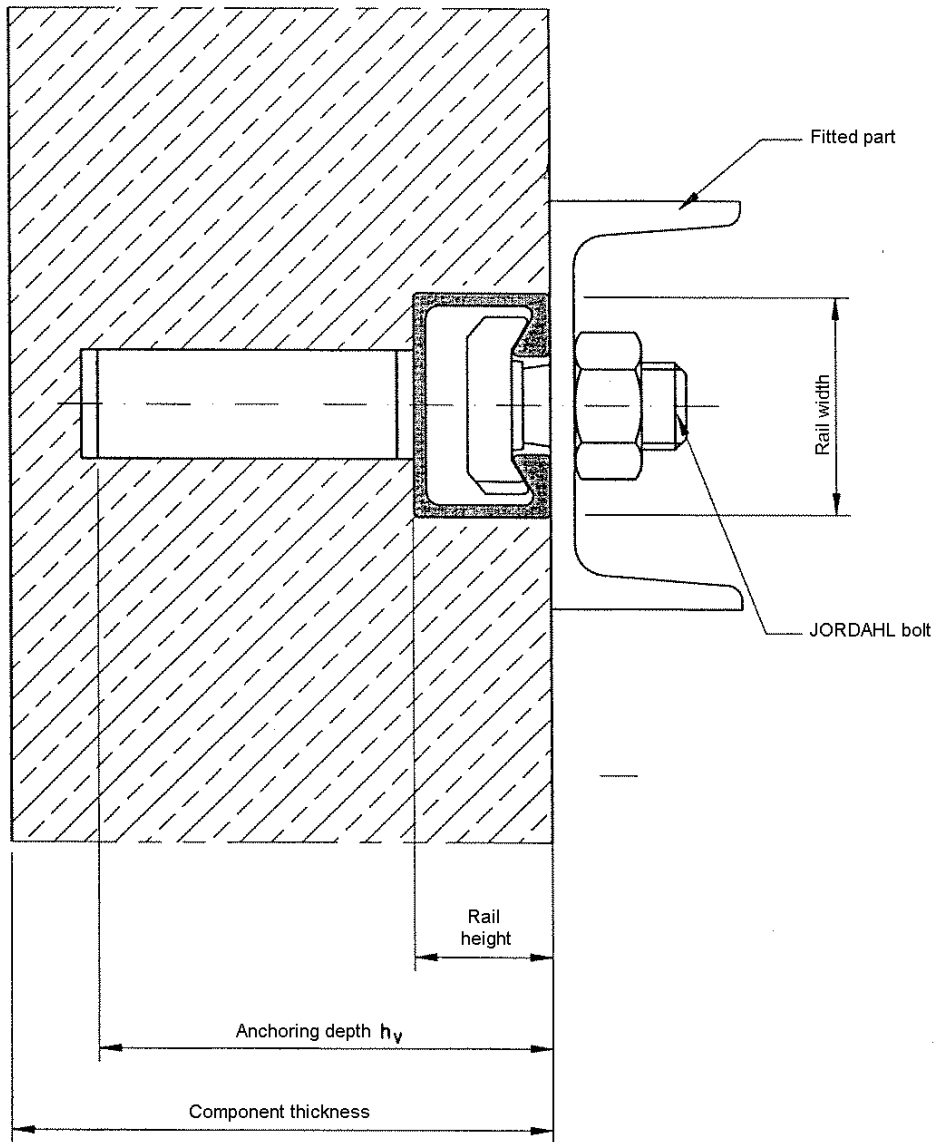

<b>JORDAHL</b> Fastening technology Deutsche Kahneisen Gesellschaft mbH Nobelstraße 51/55 12057 Berlin Tel. 030/6 82 83-02 Fax 030/6 82 83-499	<b>JORDAHL anchor rails</b> <b>Type JTA and JTA-R</b>	<b>Annex 1</b> to the General Building Approval <b>Z-21.4-151</b> dated 6 January 2003
	<b>Installed state</b>	

Note: Translation of the German original version not checked by the German Institute for Structural Engineering.  
 Every page of the German original bears the official stamp of the German Institute for Structural Engineering.

## Hot-rolled

## Cold-formed

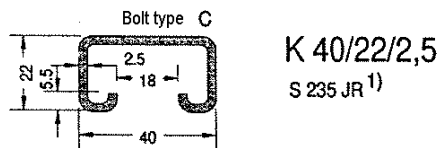
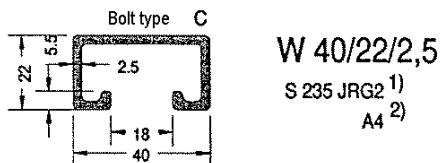
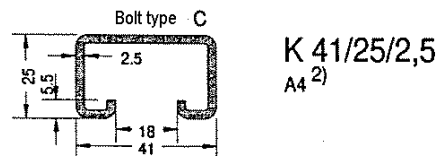
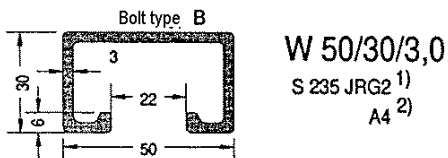
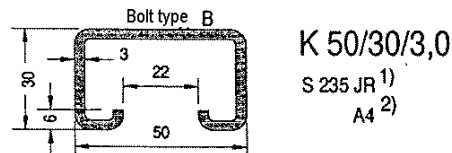
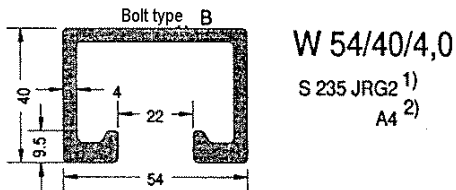
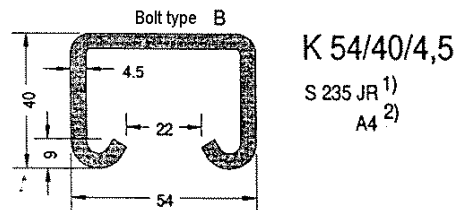
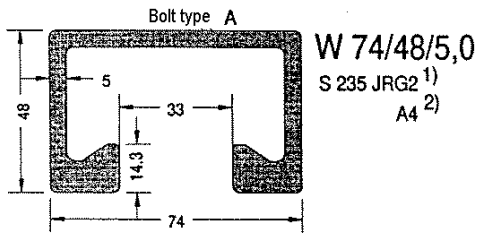

Materials:

- 1) Steel to DIN EN 10 025  
S 235 JR = 1.0037 (St 37-2)  
S 235 JRG2 = 1.0038 (RSt 37-2)  
S 275 JR = 1.0044 (R St 44-2)

- 2) Stainless steel to DIN EN 10 088  
and approved by the DIBt Z-30.3-6  
Corrosion resistance class III  
(1.4401/1.4571)

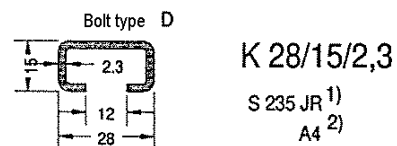
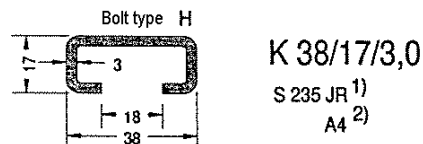

<b>JORDAHL</b> Fastening technology Deutsche Kahneisen Gesellschaft mbH Nobelstraße 51/55 12057 Berlin Tel. 030/6 82 83-02 Fax 030/6 82 83-499	<b>JORDAHL anchor rails</b> <b>Type JTA and JTA-R</b>	<b>Annex 2</b> to the General Building Approval <b>Z-21.4-151</b> dated 6 January 2003
	<b>Profile dimensions and materials</b>	

## Hot-rolled

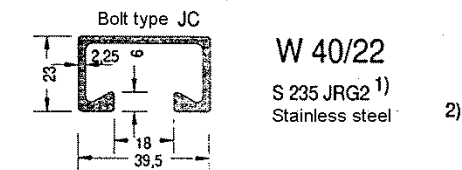
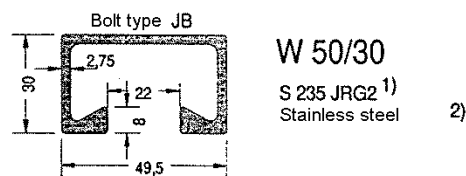
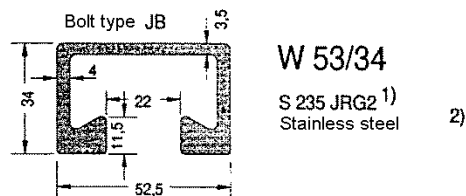
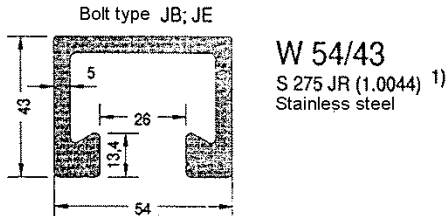
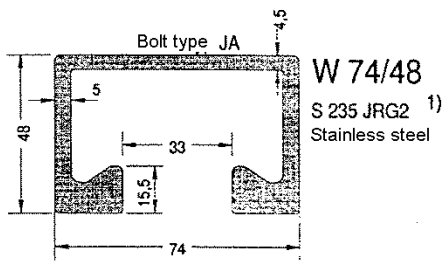

## Cold-formed

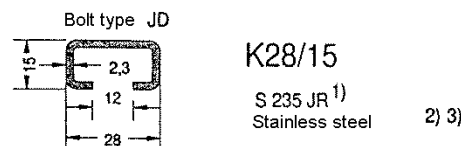
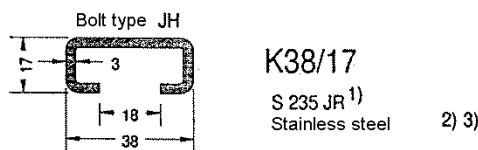
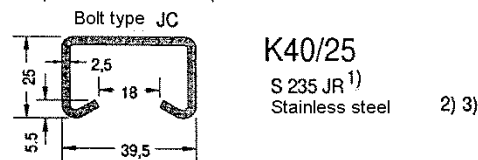
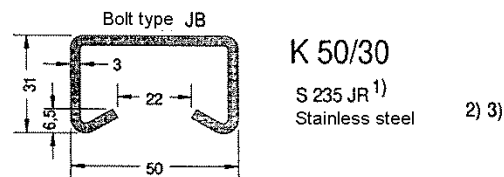
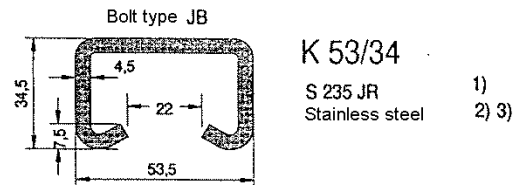
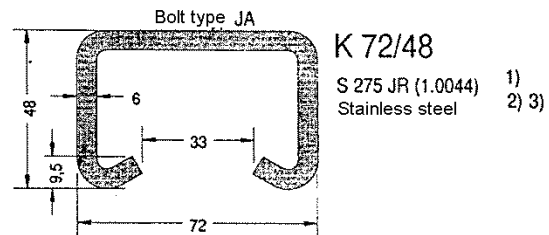

### Materials:

- 1) Steel to DIN EN 10 025  
S 235 JR = 1.0037 (St 37-2)  
S 235 JRG2 = 1.0038 (RSt 37-2)  
S 275 JR = 1.0044 (R St 44-2)

- 2) Stainless steel to DIN EN 10 088  
and approved by the DIBt Z-30.3-6  
Corrosion resistance class III  
(1.4401/1.4404/1.4571)

- 3) Stainless steel to DIN EN 10 088  
and approved by the DIBt Z-30.3-6  
Corrosion resistance class IV  
(1.4529/1.4547; 1.4462)

<b>JORDAHL</b> Fastening technology Deutsche Kahneisen Gesellschaft mbH Nobelstraße 51/55 12057 Berlin Tel. 030/6 82 83-02 Fax 030/6 82 83-499	<b>JORDAHL anchor rails</b> <b>Type JTA and JTA-R</b>	<b>Annex 3</b> to the General Building Approval <b>Z-21.4-151</b> dated 6 January 2003
	<b>Profile dimensions and materials</b>	

Table 1 : Anchor types

T anchors (Type JTA)		Round anchors (Type JTA-R)	
160 and 1125		R1	R2
Steel to DIN EN 10 025 or stainless steel to DIN EN 10 088 and Z-30.3-6 Corrosion resistance class III (A4: 1.4401/1.4404/1.4571)	Steel to DIN 17 111/DIN 1654 or stainless steel to DIN EN 10 088 and Z-30.3-6 Corrosion resistance class III (A4: 1.4401/1.4404/1.4571) Corrosion resistance class IV (KK: 1.4529 (apart from R2); FA: 1.4462)		
Anchor position Q - transverse	Anchor position L - longitudinal		

1) All welds between anchor foot and rear of rail a = 3 mm. Weld welded through on both sides

2) Short-period displacement ignition method

Table 2: Anchor arrangement

Rail length [mm]	End spacing and axial spacing of the anchors [mm]	
	End spacing	Axial spacing
100	25	50
150 <sup>1)</sup>	25	100
200 <sup>1)</sup>	25	150
250 <sup>1)</sup>	25	200
>250 <sup>1)</sup>	25	<250

1) The end spacing of round anchors may be increased from 25 mm to 35 mm

Table 3: End anchors for subsequent fitting

Type	Profile	Shank diameter d <sub>1</sub> [mm]	Anchoring depth min. h <sub>v</sub> [mm]
1	K 28/15/2.3	M 8	45
	K 28/15		
2	K 38/17/3.0	M 10	66
	K 38/17		
	W 40/22/2.5		
	K 40/22/2.5		
	W 40/22		70
	K 40/25		

1) Only for corrosion resistance class III.

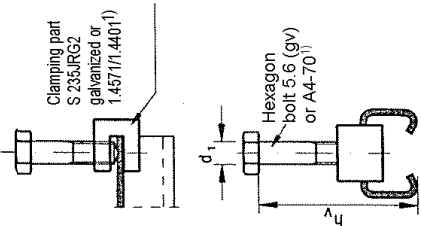

<b>JORDAHL</b> Fastening technology Deutsche Kahneisen Gesellschaft mbH Nobelstraße 51/55 12057 Berlin Tel. 030/6 82 83-02 Fax 030/6 82 83-499	<b>JORDAHL anchor rails</b> <b>Type JTA and JTA-R</b>	<b>Annex 4</b> to the General Building Approval <b>Z-21.4-151</b> dated 6 January 2003
	<b>Anchor types:</b> <b>Materials</b> <b>Arrangement of the anchors</b>	

Note: Translation of the German original version not checked by the German Institute for Structural Engineering. Every page of the German original bears the official stamp of the German Institute for Structural Engineering.

**Table 4: Dimensions of T anchors**

T anchors	For profile	Anchor type	Anchor length l [mm]	Top width a [mm]	Min. cut length b [mm]	Web thickness t [mm]	Anchor position	Anchoring depth h <sub>v</sub> [mm]	Weld thickness/length [mm]
	K 28/15/2.3 K 28/15	I 60	60	18.5	10	5	Q/L	69	3/10
	K 38/17/3.0 K 38/17	I 60	60	18.5	15	5	Q/L	71	3/15
	W 40/22/2.5 W 40/22 K 40/22/2.5 K 41/25/2.5 K 40/25	I 60	60	18.5	15	5	Q/L	76 76 79	3/15
	W 50/30/3.0 W 50/30 K 50/30/3.0 K 50/30	I 60	60	18.5	20	5	Q/L	84	3/18.5
	W 54/40/4.0 W 53/34 K 54/40/4.5 W 53/4	I 125	125	20	40	5	Q/L	149	3/40
	W 54/43	I 125	125	20	45	5	Q/L	158	3/45
	W 74/48/5.0 W 74/48 K 72/48	I 125	125	20	50	5	Q/L	167	3/50

**Table 5: Dimensions of round anchors**

	For profile	Anchor type	Shank diameter min. d <sub>1</sub> [mm]	Head diameter min. d <sub>2</sub> [mm]	Anchoring depth min. h <sub>v</sub> [mm]
R1	K 28/15/2.3 K 28/15	R 1	6.0	12.0	45
	K 38/17/3.0 K 38/17	R1	9.0	18.0	66
	W 40/22/2.5 W 40/22 K 40/22/2.5 K 40/25 K 41/25/2.5	R1	11.0	19.0	70
	W 50/30/3.0 W 50/30 K 50/30/3.0 K 50/30	R1	12.0	22.0	84
R2	K 28/15/2.3 K 28/15	R2	6.0	12.0	45
	K 38/17/3.0 K 38/17	R2	10.0	18.0	66
R3	W 40/22/2.5 W 40/22 K 40/22/2.5 K 40/25 K 41/25/2.5	R3	8.5	17.0	70
	W 50/30/3.0 W 50/30 K 50/30/3.0 K 50/30	R3	9.0	19.0	85
	W 54/40/4.0 W 53/34 K 54/40/4.5 K 53/34	R3	11.5	25.5	149
	W 54/43	R3	13.0	27.7	158
	W 74/48/5.0 W 74/48 K 72/48	R3	15.0	31.0	167

<b>JORDAHL</b> Fastening technology Deutsche Kahneisen Gesellschaft mbH Nobelstraße 51/55 12057 Berlin Tel. 030/6 82 83-02 Fax 030/6 82 83-499	<b>JORDAHL anchor rails</b> Type JTA and JTA-R	<b>Annex 5</b> to the General Building Approval <b>Z-21.4-151</b> dated 6 January 2003
	<b>Anchor types:</b> <b>Dimensions</b>	

Note: Translation of the German original version not checked by the German Institute for Structural Engineering.  
 Every page of the German original bears the official stamp of the German Institute for Structural Engineering.

## Hook-head bolts Type A, B, C

## Hammer-head bolts Type D, H

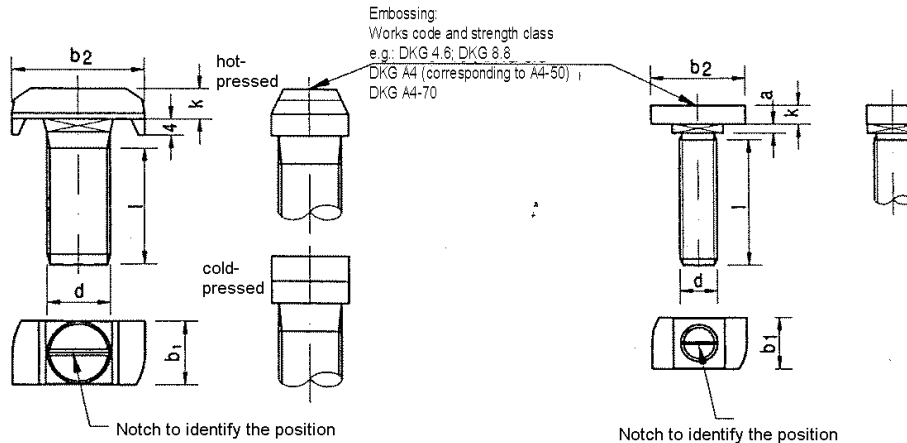

**Table 6: Bolt dimensions**

Profile JTA/JTA/R	Type	b <sub>1</sub> [mm]	b <sub>2</sub> [mm]	k [mm]	a [mm]	d [mm]	l [mm]
K28/15/2.3	<b>D</b>	10.5	22.0	4	1.7	M 6	15-50
		10.5	22.0	4		M 8	15-60
		10.5	22.0	4		M 10	15-150
K 38/17/3.0	<b>H</b>	13.0	30.5	6	2.0	M 10	20-100
		13.0	30.5	6		M 12	20-300
		16.0	30.5	6		M 16	20-200
W 40/22/2.5 K 40/22/2.5 K 41/25/2.5	<b>C</b>	13.5	33.5	7	-	M 10	20-100
		13.5	33.5	7		M 12	20-200
		16.5	33.5	8		M 16	30-300
W 50/30/3.0 W 54/40/4.0 K 50/30/3.0 K 54/40/4.5	<b>B</b>	16.5	41.5	9	-	M 10	20-100
		16.5	41.5	10		M 12	20-300
		16.5	41.5	11		M 16	20-300
		21.0	41.5	12		M 20	30-300
W 74/48/5.0	<b>A</b>	21.0	58.0	14	-	M 20	50-200
		25.0	58.0	16		M 24	60-200
		31.0	58.0	20		M 30	150-200

- Bolts:**
- Shank and thread design to DIN EN ISO 4018
  - Steel, strength class 4.6 to DIN EN ISO 898-1
  - Stainless steel for corrosion resistance class III;  
A4: 1.4401/1.4571 to DIN EN ISO 3506-1  
in strength classes A4-50 and A4-70

- Hexagon nuts:**
- Design to DIN EN ISO 4032 or 4034
  - Strength class 5 or 8 to DIN EN 20898-2
  - Stainless steel for corrosion resistance class III;  
A4: 1.4401/1.4571 to DIN EN ISO 3506-2  
in strength classes A4-50 and A4-70

- Washers:**
- DIN 125-1, DIN 9021, product class A
  - Material: steel
  - stainless steel for corrosion resistance class III;  
A4: 1.4571/1.4401 to DIN EN 10088  
And Approval Z-30.3-6 "Components and connecting elements of stainless steel"

<b>JORDAHL</b> Fastening technology Deutsche Kahneisen Gesellschaft mbH Nobelstraße 51/55 12057 Berlin Tel. 030/6 82 83-02 Fax 030/6 82 83-499	<b>JORDAHL anchor rails Type JTA and JTA-R</b>	<b>Annex 6</b> to the General Building Approval <b>Z-21.4-151</b> dated 6 January 2003
	<b>Bolts: Dimensions Materials Assignment to the profiles</b>	

## Hook-head bolts Type JA, JB, JC, JE

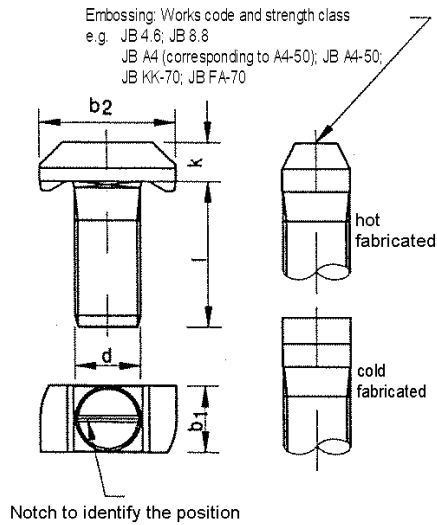
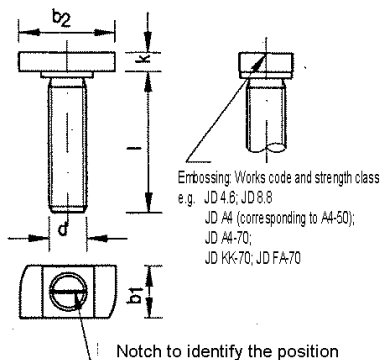

Table 7: Bolt dimensions

Profile JTA/JTA-R	Type	b <sub>1</sub> [mm]	b <sub>2</sub> [mm]	k [mm]	d [mm]	l [mm]
K 28/15	JD	11.2	22.4	4.5	M 6	15-50
		11.2	22.4	4.5	M 8	15-60
		11.2	22.4	5.0	M 10	20-150
		11.2	22.4	6.5	M 12	30-100
K 38/17	JH	16.5	30.5	6.0	M 10	20-100
		16.5	30.5	7.0	M 12	20-300
		16.5	30.5	8.0	M 16	20-300
W 40/22 K 40/25	JC	14.8	32.7	6.0	M 10	20-100
		14.8	32.7	8.0	M 12	20-200
		16.8	32.7	8.0	M 16	30-300
W 50/30 W 53/34 K 50/30 K 53/34 W 54/43	JB	17.0	41.6	9.0	M 10	20-100
		17.0	41.6	10.0	M 12	20-300
		17.0	41.6	11.0	M 16	20-300
		20.5	41.6	12.0	M 20	30-300
		20.5	41.6	12.0	M 20	30-300
W 54/43	JE	24.5	41.5	16.0	M 24	60-200
W 74/48 K 72/48	JA	25.0	58.0	14.0	M 20	50-200
		25.0	58.0	20.0	M 24	60-200
		26.0	58.0	20.0	M 27	150-200
		31.0	58.0	20.0	M 30	150-200

## Hammer-head bolts Type JD, JH



### Bolts:

- Shank and thread design to DIN EN ISO 4018
  - Steel, strength class 4.6 to DIN EN ISO 898-1
  - Stainless steel in accordance with Z-30.3-6 and DIN EN ISO 3506-1:
- For corrosion resistance class III: A4; 1.4401/1.4404/1.4571 strength class 50 & 70
- For corrosion resistance class IV: KK: 1.4529, strength class 50 & 70; FA: 1.4462, strength class 70

### Hexagon nuts:

- Design to DIN EN ISO 4032 or 4034
  - Strength class 5 or 8 to DIN EN 20898-2
  - Stainless steel according to Z-30.3-6 and DIN EN ISO 3506-2:
- For corrosion resistance class III: A4; 1.4401/1.4404/1.4571 strength class 50 & 70
- For corrosion resistance class IV: KK: 1.4529, strength class 50 & 70; FA: 1.4462, strength class 70

### Washers:

- DIN 125-1, DIN 9021, product class A
- Material steel
  - Stainless steel:
- Corrosion resistance class III: 1.4401/1.4404/1.4571 and  
Corrosion resistance class IV: 1.4529; 1.4462 to DIN EN 10 888  
and Approval Z-30.3-6 "Components and connecting elements of stainless steels"
- Hexagon nuts and washers for corrosion resistance class IV are given the following code: - 1.4529: KK or 4529
- 1.4462: FA or 4462

Table 8: JORDAHL washers

Type	Associated profile	Dimensions	b [mm]	t [mm]
JUS 40	K 40/25	M 10, M 12, M 16	40	4
JUS 50	K50/30 K53/34	M 10, M 12	50	5
		M 16, M 20		
JUS 72	K72/48	M 20, M 24 M 27, M 30	72	6

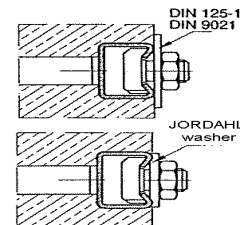

<b>JORDAHL</b> Fastening technology Deutsche Kahneisen Gesellschaft mbH Nobelstraße 51/55 12057 Berlin Tel. 030/6 82 83-02 Fax 030/6 82 83-499	<b>JORDAHL anchor rails</b> Type JTA and JTA-R	<b>Annex 7</b> to the General Building Approval <b>Z-21.4-151</b> dated 6 January 2003
	<b>Bolts:</b> <b>Dimensions</b> <b>Materials</b> <b>Assignment to the profiles</b>	

**Table 9: Areas of use depending on corrosion protection**

	Corrosion protection of the constructional parts			Intended use
	Rail	Anchor	Bolt, nut, washer	
1	plain rolled	plain rolled	no corrosion protection	Use only possible if all the fixing elements are protected, depending on the ambient conditions, by a minimum concrete covering to DIN 1045:1988-07, Table 10 or DIN 1045-1:2001-07, Table 4
2	Hot galvanized (Coating ≥ 50 µm)	Hot galvanized (Coating ≥ 50 µm)	Electrogalvanized (Coating ≥ 5 µm)	Concrete components in closed rooms, e.g. dwellings, offices, schools, hospitals, retail premises, except wet rooms
3	Hot galvanized (Coating ≥ 50 µm)	Hot galvanized (Coating ≥ 50 µm)	Electrogalvanized (Coating ≥ 40 µm)	Concrete components in interior rooms with normal atmospheric humidity (including kitchen, bathroom and washroom in dwellings) to DIN 1045:1988-07, Table 10, line 1 or DIN 1045-1:2001-07, Table 3 (XC1)
4	Stainless steel 1.4401/1.4404/1.4571 to DIN EN 10 088  Welded-on anchor plain rolled 1) 2)			Strength class 50, 70  Constructions in corrosion resistance class III to Z-30.3-6, e.g. in wet rooms, in the open air, industrial atmospheres and close to the sea, without further corrosive loading, see Section 3.1.2
5	Stainless steel 1.4529/1.4547; 1.4462 <sup>3)</sup> to DIN EN 10 088		Stainless steel 1.4529 Strength class 50 & 70  Stainless steel 1.4462 <sup>3)</sup> Strength class 70	Constructions in corrosion resistance class IV to Z-30.3-6 with high corrosive loading by chlorides and sulphur dioxide (including elevated concentrations of the pollutants, e.g. components in seawater and road tunnels), see Section 3.1.2  Swimming baths: see Table 10 of the General Building Approval Z-30.3-6

- 1) Only permissible for profile K 28/15 and K 38/17 of stainless steel
- 2) With regard to the corrosion protection of the welded-on anchors, the concrete covering according to Table 10 may be used.
- 3) According to Z-30.3-6, not permissible for swimming bath atmospheres.

**Table 10: Concrete covering c**

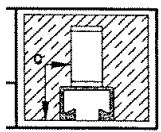
Profile JTA	K 40/22/2.5 W 40/22/2.5 W 40/22	K 41/25/2.5 K 40/25	K 50/30 K 50/30/3.0 K 53/34 W 50/30 W 50/30/3.0 W 53/34	K 54/40/4.5 W 57/40/4.0	W 54/43	K 72/48 W 74/48/5.0 W 74/48	
c [mm]	30	35	40	45	50	60	

**Identification of the Jordahl anchor rails**

The identification (code) is to be made permanently on the rear of the rails (inside or outside) or on the rail web. It can be made by means of a sticker, imprint, embossing or other suitable measures.

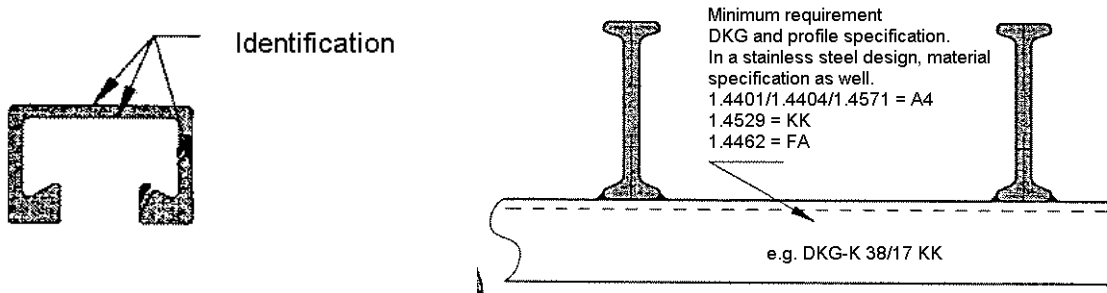

<b>JORDAHL</b> Fastening technology Deutsche Kahneisen Gesellschaft mbH Nobelstraße 51/55 12057 Berlin Tel. 030/6 82 83-02 Fax 030/6 82 83-499	<b>JORDAHL anchor rails</b> Type JTA and JTA-R	<b>Annex 8</b> to the General Building Approval <b>Z-21.4-151</b> dated 6 January 2003
	<b>Corrosion protection</b> Identification	

Note: Translation of the German original version not checked by the German Institute for Structural Engineering. Every page of the German original bears the official stamp of the German Institute for Structural Engineering.

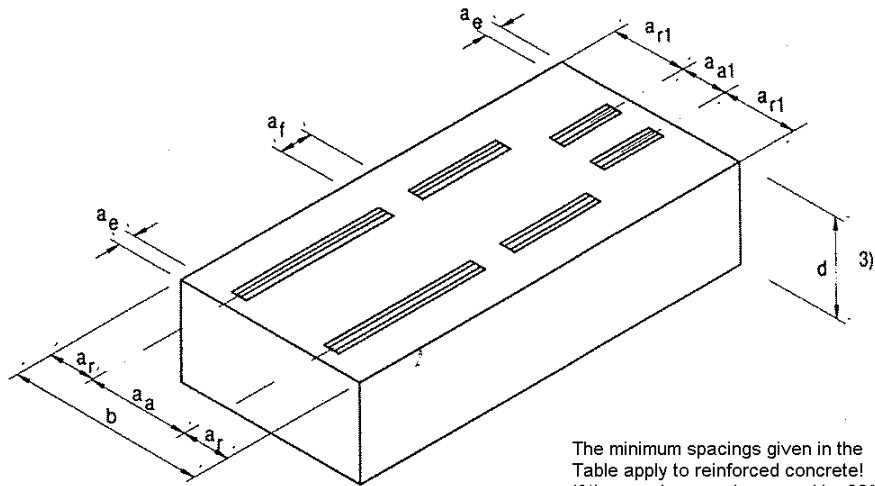

The minimum spacings given in the Table apply to reinforced concrete! If the spacings are increased by 30%, no requirements are placed on the reinforcement.

**Table 11: Minimum spacings and minimum component dimensions**

Profile JTA	5) a <sub>r6</sub> [cm]	a <sub>a</sub> [cm]	a <sub>e</sub> [cm]	a <sub>f</sub> [cm]	b <sup>2)</sup> [cm]	d <sup>3)</sup> [cm]	Pairs of rails	
							a <sub>r1</sub> [cm]	a <sub>a1</sub> [cm]
K 28/15/2.3 K 28/15	5	10	4	8	10		5	10
K 38/17/3.0 K 38/17	7.5	15	5	10	15		10	10
W 40/22/2.5 W 40/22 K 40/22/2.5 K 40/25 K 41/25/2.5	10	20	8(7) <sup>1)</sup>	20	20		14	12.5
W 50/30/3.0 W 50/30 K 50/30/3.0 K 50/30	15	30	13(10) <sup>1)</sup>	25	30		22.5	15
W 54/40/4.0 W 53/34 K 54/40/4.5 K 53/34 W 54/43	20	40	17.5	35	40		–	–
W 74/48/5.0 W 74/48 K 72/48	25	50	22.5	45	50		–	–

- 1) Dimensions in brackets ( ) apply to existing a<sub>r</sub> ≥ 2 permissible a<sub>r</sub>
- 2) Applies when one rail is used
- 3) Results from the smallest possible length of the anchors and the required concrete covering in accordance with DIN 1045
- 4) Only central tension permissible
- 5) When loaded in transverse tension and oblique tension, the spacing a<sub>r</sub> from the unloaded edge may be reduced to a<sub>r</sub>/2 or min. 5 cm if rear-suspended reinforcement is used analogous to Annex 12
- 6) Edge spacing under fire loading for reinforced concrete floors: see Annex 14

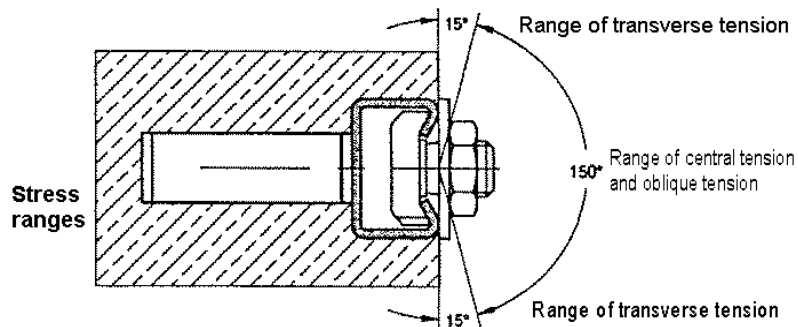

<b>JORDAHL</b> Fastening technology Deutsche Kahneisen Gesellschaft mbH Nobelstraße 51/55 12057 Berlin Tel. 030/6 82 83-02 Fax 030/6 82 83-499	<b>JORDAHL anchor rails</b> <b>Type JTA and JTA-R</b>	<b>Annex 9</b> to the General Building Approval <b>Z-21.4-151</b> dated 6 January 2003
	<b>Axial and edge spacings</b> <b>Stress ranges</b>	

Note: Translation of the German original version not checked by the German Institute for Structural Engineering. Every page of the German original bears the official stamp of the German Institute for Structural Engineering.

**Table 12: Permissible loads on the anchor rails  
for all concrete strength classes  $\geq$  C 20/25 (B25) <sup>4)</sup>**

Profile JTA	Associated bolts <sup>3)</sup>	Permissible loads [kN] <sup>2)</sup>								
		Central tension and oblique tension $\alpha \geq 15^\circ$ <sup>1)</sup>						Transverse load $\alpha \leq 15^\circ$ <sup>1)</sup>		
		Individual loads			Paired loads			Individual loads		Paired loads
Rail length [cm]		10	15 to 25	>25	20 to 25	>25	10	$\geq 15$	$\geq 20$	
K 28/15/2.3 K 28/15	D-M 8 JD-M 8 D-M 10 JD-M 10 D-M 12 JD-M 12	3.5	3.5	3.0	3.0	2.0	3.5	3.5	3.0	
K 38/17/3.0 K 38/17	H-M 12 JH-M 12 H-M 16 JH-M 16	7.0	7.0	4.5	4.5	3.0	8.0	8.0	4.5	
W 40/22/2.5 W 40/22 K 40/22/2.5 K 40/25 K 41/25/2.5	C-M 16 JC-M 16	–	8.0	6.0	6.0	4.0	–	10.0	6.0	
W 50/30/3.0 W 50/30 K 50/30/3.0 K 50/30	B-M 16 JB-M 16 B-M 20 JB-M 20	–	12.0	10.0	7.0	5.0	–	12.0	7.0	
W 54/40/4.0 W 53/34 K 54/40/4.5 K 53/34	B-M 20 JB-M 20	–	22(25)	22(25)	11(12.5)	11(12.5)	–	22(25)	11(12.5)	
W 54/43	JE-M 24	–	27(32)	27(32)	13.5(16)	13.5(16)	–	27(32)	13.5(16)	
W 74/48/5.0 W 74/48 K 72/48	A-M 24 JA-M 24 A-M 27 JA-M 27 A-M 30 JA-M 30	–	27(32)	27(32)	13.5(16)	13.5(16)	–	27(32)	13.5(16)	

1) Stress ranges: see Annex 9

2) Bracketed values apply when C 30/37 (B35) is used and are only permissible when the expansion of the concrete transverse to the rail longitudinal axis is prevented by reinforcement (one rod each of BSt 500S,  $d_s \geq 8$  mm at the rail ends) or by transverse pressure

3) If smaller bolts are used in accordance with Annex 6 or 7, the permissible load on the bolts (see below) must not be exceeded

4) In the case of anchoring in concrete of strength class C 12/15 (B15), the permissible loads for C 20/25 (B25) must be reduced by the factor 0.7. In the case of anchoring in lightweight concrete (dense structure)  $\geq$  LC 25/28 (LB 25) - additive expanded clay, expanded slate or pumice - the permissible loads must be reduced by the factor 2/3.

Concrete strength classes to DIN 1045-1:2001-07  
or DIN: 1045:1988-07 (bracketed values)

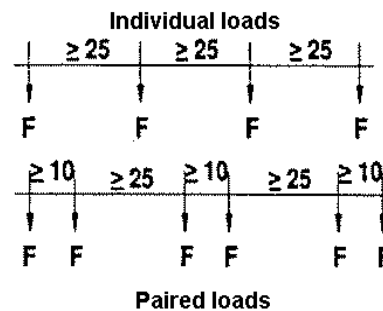

**Table 13: Tightening torques and permissible loads on the bolts**

Bolt diameter	Tightening torque [Nm]	Permissible load on the bolts [kN] when stressed in tension, oblique tension or transverse tension		
		Steel strength class 4.6	Stainless steel strength class 50	Stainless steel strength class 70
M 6	3	2.2	2.2	3.0
M 8	8	4.0	4.0	5.5
M 10	15	6.4	6.4	8.7
M 12	25	9.3	9.3	12.6
M 16	60	17.3	17.3	23.6
M 20	120	27.0	27.0	36.8
M 24	200	38.8	38.8	
M 27	300	50.5	50.5	
M 30	400	61.7		

**Table 14: Permissible Bending moments [Nm] on the bolts** based on upper edge of rail or concrete

Bolt diameter	M 6	M 8	M 10	M 12	M 16	M 20	M 24	M 27	M 30
Through hole in component to be connected [mm]	7.0	9.0	12.0	14.0	18.0	22.0	26.0	30.0	33.0
Strength class 4.6	2.0	5.0	10.0	17.5	44.4	86.5	149.9	221.9	299.9
Stainless steel, str. class 50	1.8	4.4	8.7	15.3	38.8	75.7	130.9	–	262.4
Stainless steel, str. class 70	3.8	9.4	18.7	32.8 <sup>1)</sup>	83.3 <sup>2)</sup>	162.3	–	–	–

1) For the profile K 28/15/2.3; K 28/15, permissible bolt tightening torque must be reduced to 30.0 Nm for a rail length  $L > 25$  cm.  
2) For the profile K 38/17/3.0; K 38/17, permissible bolt tightening torque must be reduced to 65.2 Nm for a rail length  $L > 25$  cm.

<b>JORDAHL</b> Fastening technology Deutsche Kahneisen Gesellschaft mbH Nobelstraße 51/55 12057 Berlin Tel. 030/6 82 83-02 Fax 030/6 82 83-499	<b>JORDAHL anchor rails</b> Type JTA and JTA-R	<b>Annex 10</b> to the General Building Approval <b>Z-21.4-151</b> dated 6 January 2003
	<b>Permissible loads on the anchor rails and bolts</b>	

Note: Translation of the German original version not checked by the German Institute for Structural Engineering.  
Every page of the German original bears the official stamp of the German Institute for Structural Engineering.

**Table 15: Permissible cycle sizes <sup>1)</sup> for a load cycle of  $N = 2 * 10^6$**

Table 15:

Profile	Permissible cycle size $\Delta F = F_0 - F_u$ [kN] under tensile stress <sup>2)</sup>	Anchor type
W 40/22/2.5	2.0	I 60
W 40/22		I 60, R1, R3
W 50/30/3.0	2.4	I 60
W 50/30		I 60, R1, R3
W 54/40/4.0 W 53/34	7.0	I 125
W 74/48/5.0 W 74/48	7.0	I 125

- 1) The application is permissible only in reinforced components .  
When incorporated in the tension zone of reinforced concrete components, produced by load stress, the passing on of the forces must be verified.
- 2) The load specifications apply only to hot-rolled anchor rails in the plain rolled or galvanized designs with T anchors placed transversely and the specified round anchors.

Only the associated bolts to Annex 10 (Table 2) are permissible.

Example: **JTA-W 50/30**  
**l > 25 cm**

**According to Annex 10** 10.0 kN  
**- tensile threshold load - 2.4 kN**  
**= remaining tensile stress** 7.6 kN

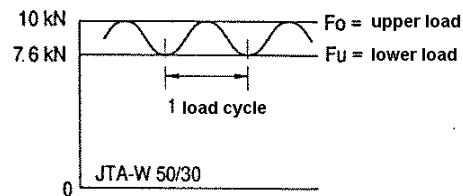

**Permissible cycle sizes  $\Delta F$  as a function of the load cycles  $N$  experienced**

Given fewer load cycles than  $N = 2 * 10^6$ , the permissible cycle sizes can be taken from the following graph.

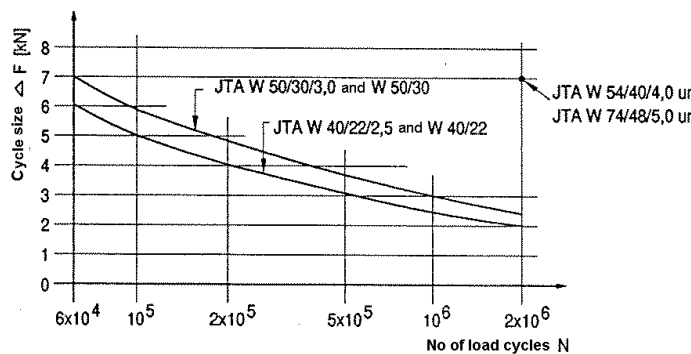

<b>JORDAHL</b> Fastening technology Deutsche Kahneisen Gesellschaft mbH Nobelstraße 51/55 12057 Berlin Tel. 030/6 82 83-02 Fax 030/6 82 83-499	<b>JORDAHL anchor rails</b> <b>Type JTA and JTA-R</b>	<b>Annex 11</b> to the General Building Approval <b>Z-21.4-151</b> dated 6 January 2003
	<b>Permissible cycle sizes</b>	

Note: Translation of the German original version not checked by the German Institute for Structural Engineering.  
Every page of the German original bears the official stamp of the German Institute for Structural Engineering.

**Reduced edge spacing under central tensile stress and arrangement of additional reinforcement to Section 3.2.5 for profiles K 28/15/2.3 and K 28/15 to W 50/30/3.0 and W 50/30**

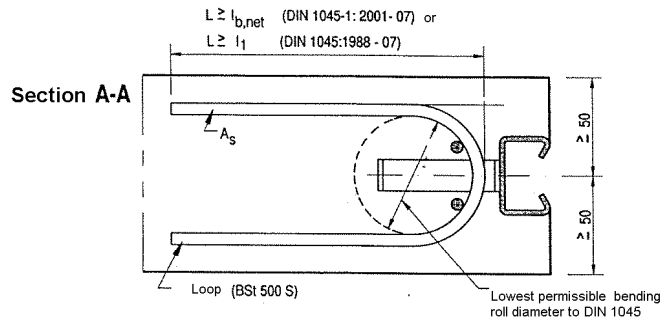

$$\text{found } A_s = \frac{\text{perm. } F}{4 \times \sigma_s}$$

$\sigma_s = 8 \text{ kN/cm}^2$  applicable steel stress  
 $4 \times \sigma_s \text{ perm. } F = \text{max. load [kN] to Annex 10}$   
 $A_s = \text{reinforcement cross section [cm}^2\text{] of one leg of a loop}$

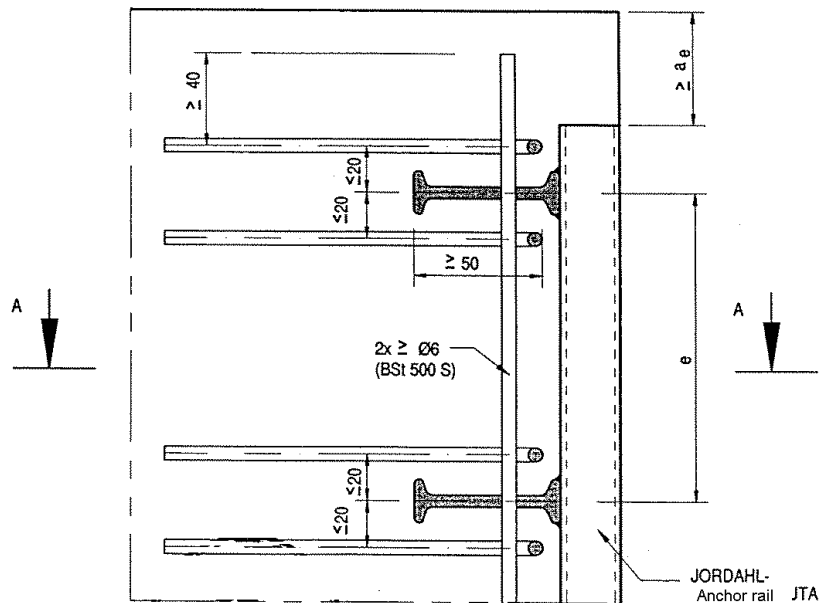

<b>JORDAHL</b> Fastening technology Deutsche Kahneisen Gesellschaft mbH Nobelstraße 51/55 12057 Berlin Tel. 030/6 82 83-02 Fax 030/6 82 83-499	<b>JORDAHL anchor rails</b> <b>Type JTA and JTA-R</b>	<b>Annex 12</b> to the General Building Approval <b>Z-21.4-151</b> dated 6 January 2003
	<b>Rear-suspended</b> <b>reinforcement with reduced</b> <b>edge spacing</b>	

Note: Translation of the German original version not checked by the German Institute for Structural Engineering. Every page of the German original bears the official stamp of the German Institute for Structural Engineering.

**Table 16:**  
**Permissible loads [kN] <sup>1)</sup> under fire loading corresponding to fire resistance class F90 and F60 (bracketed values) for JORDAHL anchor rails embedded in concrete, taking into account the associated JORDAHL hammer-head and hook-head bolts**

Profile <sup>2)</sup> JTA	Permissible load [kN] JORDAHL hammer-head and hook-head bolts strength class 4.6 stainless steel; strength class 50, 70				
	M8	M10	M12	M16	≥ M20
K 28/15/2.3 K 28/15	0.5 (0.7)	0.6 (0.8)	0.6 (0.8)	–	–
K 38/17/3.0 K 38/17	–	0.6 (0.8)	0.6 (0.8)	0.6 (0.8)	–
W 40/22/2.5 W 40/22 K 40/22/2.5 K 40/25 K 41/25/2.5	–	1.3	1.8	4.0	–
W 50/30/3.0 W 50/30 K 50/30/3.0 K 50/30	–	1.3	1.8	4.0	4.0
W 54/40/4.0 W 53/34 K 54/40/4.5 K 53/34	–	1.3	1.8	4.0	4.0
W 54/43	–	–	–	–	4.0 (M 24)
W 74/48/5.0 W 74/48 K 72/48	–	–	–	–	4.0

- 1) Stress ranges according to Annex 9  
 In the case of spaced assembly, the connections may be loaded only under central tension when stressed by fire.
- 2) Profiles of plain rolled or galvanized steel and of stainless steel.

<b>JORDAHL</b> Fastening technology Deutsche Kahneisen Gesellschaft mbH Nobelstraße 51/55 12057 Berlin Tel. 030/6 82 83-02 Fax 030/6 82 83-499	<b>JORDAHL anchor rails</b> <b>Type JTA and JTA-R</b>	<b>Annex 13</b> to the General Building Approval <b>Z-21.4-151</b> dated 6 January 2003
	<b>Fire loading:</b> <b>Permissible loads on the bolts</b>	

Note: Translation of the German original version not checked by the German Institute for Structural Engineering.  
 Every page of the German original bears the official stamp of the German Institute for Structural Engineering.

**Reinforced standard concrete coverings stressed by fire on one side with JORDAHL anchor rails embedded in concrete**

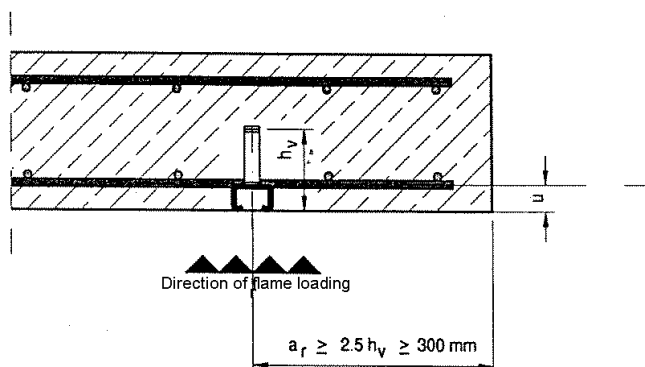

**Table 17:**  
**Required maximum axial spacing u [mm] with a fire resistance period F 60 and F 90 in the area of the JORDAHL anchor rails**

Profile JTA	Required axial spacing u [mm] for fire resistance period	
	60 minutes	90 minutes
K 28/15/2.3 K 28/15	35	45
K 38/17/3.0 K 38/17		
W 40/22/2.5 W 40/22 K 40/22/2.5 K 40/25 K 41/25/2.5	35	45
W 50/30/3.0 W 50/30 K 50/30/3.0 K 50/30	35	45
W 54/40/4.0 W 53/34 K 54/40/4.5 K 53/34	50	50
W 54/43	50	50
W 74/48/5.0 W 74/48 K 72/48		

<b>JORDAHL</b> Fastening technology Deutsche Kahneisen Gesellschaft mbH Nobelstraße 51/55 12057 Berlin Tel. 030/6 82 83-02 Fax 030/6 82 83-499	<b>JORDAHL anchor rails</b> <b>Type JTA and JTA-R</b>	<b>Annex 14</b> to the General Building Approval <b>Z-21.4-151</b> dated 6 January 2003
	<b>Fire loading:</b> <b>anchor rails in reinforced</b> <b>concrete coverings</b>	

Note: Translation of the German original version not checked by the German Institute for Structural Engineering. Every page of the German original bears the official stamp of the German Institute for Structural Engineering.

## Reinforced standard concrete beams stressed by fire on three sides

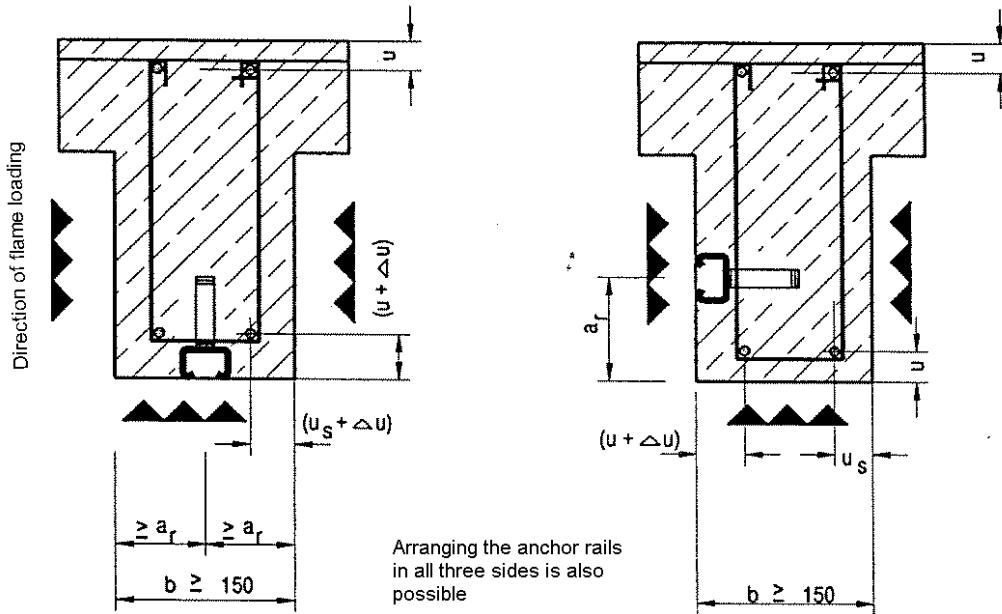

**Table 18:**

### Increasing the axial spacing $u$ [mm] of the tensile reinforcement

The axial spacings  $u$  and  $u_s$  required in accordance with DIN 4102-4:1994-03 must be increased by the amount  $\Delta u$  when anchor rails are installed.

Profile JTA	$\Delta u$ [mm] <sup>1)</sup> for F 90, based on beam width			
	$b = 150$ [mm]	$b = 250$ [mm]	$b = 300$ [mm]	$b \geq 400$ [mm]
K 28/15/2.3 K 28/15	10	10	10	10
K 38/17/3.0 K 38/17				
W 40/22/2.5 W 40/22 K 40/22/2.5 K 40/25 K 41/25/2.5	15	10	10	10
W 50/30/3.0 W 50/30 K 50/30/3.0 K 50/30	20	15	15	15
W 54/40/4.0 W 53/34 K 54/40/4.5 K 53/34				
W 54/43	35	25	20	15
W 74/48/5.0 W 74/48 K 72/48				

1) Intermediate values may be interpolated linearly.

<b>JORDAHL</b> Fastening technology Deutsche Kahneisen Gesellschaft mbH Nobelstraße 51/55 12057 Berlin Tel. 030/6 82 83-02 Fax 030/6 82 83-499	<b>JORDAHL anchor rails</b> <b>Type JTA and JTA-R</b>	<b>Annex 15</b> to the General Building Approval <b>Z-21.4-151</b> dated 6 January 2003
	<b>Fire loading: anchor rails in</b> <b>reinforced concrete beams</b>	

Note: Translation of the German original version not checked by the German Institute for Structural Engineering. Every page of the German original bears the official stamp of the German Institute for Structural Engineering.

## Reinforced standard concrete columns loaded by fire on four sides

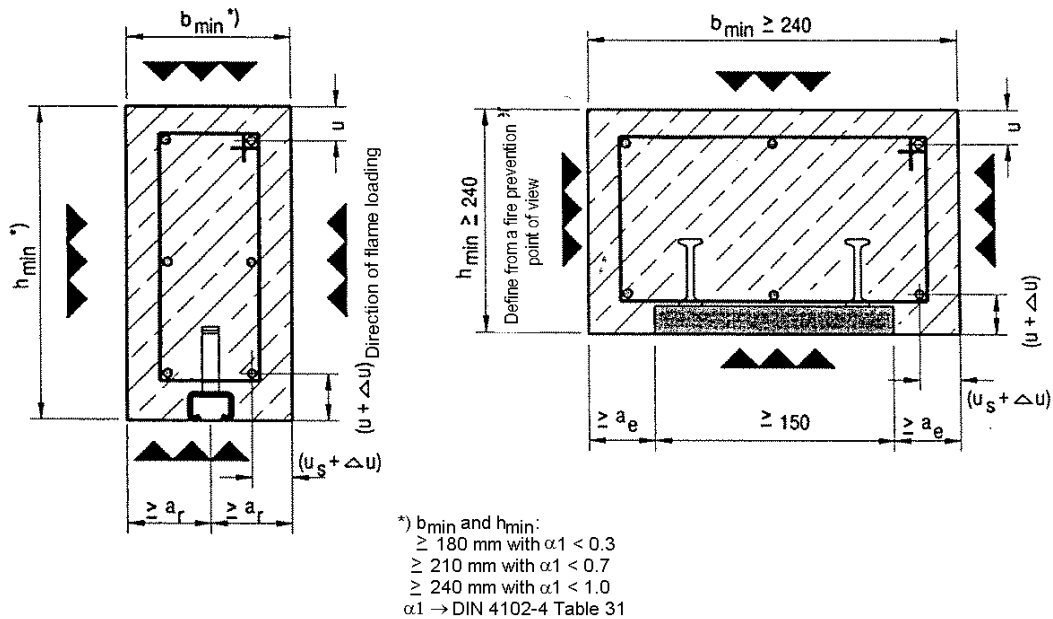

**Table 19:**

**Increasing the axial spacing  $u$  [mm] of the concrete steel reinforcement by  $\Delta u$**   
 The axial spacings  $u$  and  $u_s$  required in accordance with DIN 4102:1994-03 must be increased by the amount  $\Delta u$  when anchor rails are installed.

Profile JTA	$\Delta u$ [mm] <sup>1)</sup> for F 90, based on column cross section of				
	$b = 180$ <sup>2)</sup> [mm]	$b = 210$ <sup>3)</sup> [mm]	$b = 240$ [mm]	$b = 300$ [mm]	$b \geq 400$ [mm]
K 28/15/2.3 K 28/15	10	10	10	10	10
K 38/17/3.0 K 38/17					
W 40/22/2.5 W 40/22 K 40/22/2.5 K 40/25 K 41/25/2.5	15	10	10	10	10
W 50/30/3.0 W 50/30 K 50/30/3.0 K 50/30	20	15	15	15	15
W 54/40/4.0 W 53/34 K 54/40/4.5 K 53/34					
W 54/43	35	25	20	15	15
W 74/48/5.0 W 74/48 K 72/48					

1) Intermediate values may be interpolated linearly.

2) Utilization factor  $\alpha_1$  according to Section 3.13.2.2 DIN 4102-4  $\leq 0.3$

3) Utilization factor  $\alpha_1$  according to Section 3.13.2.2 DIN 4102-4  $\leq 0.73$

<b>JORDAHL</b> Fastening technology Deutsche Kahneisen Gesellschaft mbH Nobelstraße 51/55 12057 Berlin Tel. 030/6 82 83-02 Fax 030/6 82 83-499	<b>JORDAHL anchor rails</b> Type JTA and JTA-R	<b>Annex 16</b> to the General Building Approval <b>Z-21.4-151</b> dated 6 January 2003
	<b>Fire loading:</b> anchor rails in reinforced concrete columns	